

Mini Merlin

SPAN CALIBRATION GUIDE

Regular maintenance and calibration of the sensors by trained technicians is recommended. Inspections and services must be documented and executed at regular intervals. The frequency must be determined and observed by the person responsible for the gas warning system according to all regulatory, code and legal requirements. The inspection interval is normally 12-18 months to retain optimum safety.

Safety Statements

- ⚠ Acknowledge any alarms or faults before attempting to begin the calibration process.
- ⚠ When entering span adjustment function, the detector will enter special mode, and will remain offline until the adjustment is successful, or power is reset.
- ⚠ At elevations higher than 6,560' (2,000m), calibration will result in a lower reading.
- ⚠ Response and recovery times may vary with when performed outside the parameters of factory calibration i.e., temperature, air velocity and flow rate.
- ⚠ Give at least seven (7) minutes between testing the same unit or until gas has fully dispersed.
- ⚠ Sensors should be calibrated if the measuring range has been exceeded, which can shorten the sensor lifetime and/or reduce its sensitivity.

Span Calibration Test Gases

- ⚠ All calibration test gases are classified as non-flammable and non-toxic, however, they do contain gas under pressure and may explode if heated and cause asphyxiation in very high concentrations.
- ⚠ S&S gas mixtures are prepared using equipment traceable to N.P.L / ISO standards.
- ⚠ Cylinders should always be stored in the vertical position and secured to prevent them falling over.
- ⚠ Ensure valve/regulators are screwed and secured tight before use and ensure valves are closed after use.
- ⚠ Safety Data Sheets are available on request.



Target Gas	Formula	Concentration	Balance/Mix	Flow Rate	°F/°C	Application Time
Carbon Monoxide	CO	120ppm	Nitrogen / Air	0.5L Per/Min	59-86°F 15-30°C	<60s
Natural Gas/Methane	CH ₄	0.5% BV (10% LEL)				<120s
Propane (LPG)	C ₃ H ₈	0.2% BV (10% LEL)				

All persons required to handle gas should be able to identify the following: -

- The cylinder and its contents.
- Properties and hazards of the gases.
- The 'use by' date and unique batch number.

S&S Northern supply calibration kits

Procedure (CO)

Equipment: 1x M3 Socket Wrench / 1x Tweezers or metal jumper / 1x Calibration Kit

1. Preparation

Fix any regulators, pipes, and mask to gas cylinder.
Unscrew the four bolts of the device using an M3 socket wrench.
Carefully remove the front fascia to expose the circuit board.

BE CAREFUL OF LINE VOLTAGE CONNECTIONS

To access the calibration function of the device, remove and re-introduce Power.
The screen will show 'Press Touch Button for 3s to Start'.

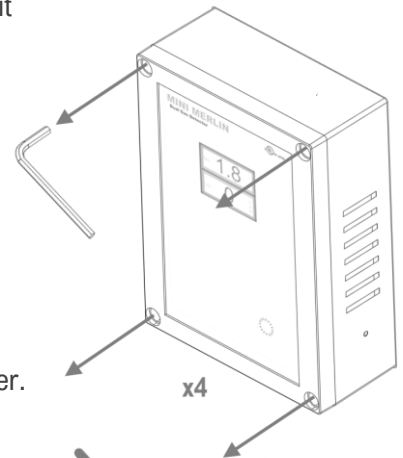

2. Prompt CO Calibration

Press the Touch Button for 3s to prompt initialization screen.
During the initialization – short out the [CAL1] header with tweezers.
Hold tweezers in place until a 'beep' is heard.

CO Calibration
The screen will now show '**CO CALIBRATION**'.
The device is now in Span Calibration Mode.

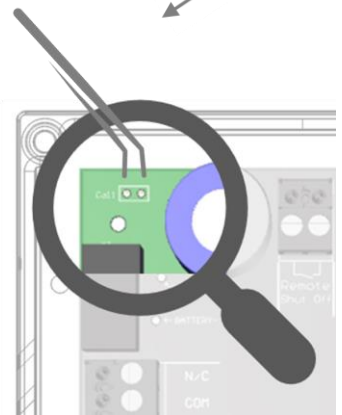

3. Apply Calibration Gas

Open valve (before applying the mask) to allow for pressure release.
Hold mask over the CO sensor and apply gas.

CO Calibration
SUCCESSFUL
Apply gas until '**SUCCESSFUL**' appears on screen.
The device will automatically restart.

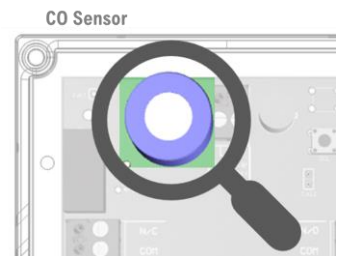

4. Calibration Complete.

If unsuccessful, repeat process, ensure gas flow rate, temperature and concentration parameters are met.

5. Turn off gas flow and remove mask.

Allow sensor to recover/stabilise before returning to normal operation.

6. Secure front fascia with M4 bolts.

7. Repeat process for LPG / CH4

Short [CAL2] header and apply gas to **LPG / CH4** sensor.

info@snsnorthern.com